



Tow-Trust Towbars

Important: Please read General Notes overleaf before fitting



Issue 5

TALKO1 ALKO BASED MOTORHOMES

Item	Qty	Description	Item	Qty	Description
A	1	Central Section	J	2	M16 x 60 Bolts & Nyloc Nuts
B	2	Handed End Sections	K	6	M14 x 100 Bolts & Nyloc Nuts
C	1	Central Clamp Plate	K1	2	M14 x 90 Bolts & Nyloc Nuts
D	2	Side Plates	L	12	M12 x 50 Bolts Grade 10.9, 10 Nyloc Nuts & 2 S/P Washers
E	2	Side Arms	M	22	12 x 25 Flat Washers
F	2	(Small) 12.5mm End Spacers	N	16	14 x 27 Flat Washers
G	2	(Large) 10mm Chassis Spacers/Clamp Plates	P	8	41 O/D x 45.5mm H/D Spacer Tube
H	1	T1 Towball	R	6	M12 Black Caps
H1	1	SOCKET PLATE 5	S	16	M14 Black Caps
			T	2	M16 Black Caps

TOWBAR INSTALLATION:

1. First identify your motorhome against the fitting instruction guidelines. (E.g. Swift #1).
 2. Now you have paired up your motorhome with the instruction loosely assemble the crossmember to the required length Using Items **K** with Items **N** ensuring all 8 spacer tubes (Item **P**) are fitted. (Keep crossmember loose until final torque of the complete assembly).
1. **Swift #2 / Swift #5 / Swift #8 / Swift #9 / Bailey #1:** Using Item **L** with Item **M** loosely fix Items **D** to the vehicles chassis/ chassis extension. Item **G** can be used as a clamp plate on these vehicles, ensuring the chassis/ chassis extension is sandwiched between Item **D** and Item **G**.
 2. Using Item **L** with Item **M** fix Item **A** between each side plate (Items **D**).
 3. Using Item **J** fix Item **H** (Towball) and wiring plate (Not supplied in this kit) to Item **A** ensuring Item **C** is fitted behind the face plate. (Please ensure the Towbar face plate is sandwiched between Item **C** and Item **H**).
 4. Fully tighten all fixings ensuring the Towbar is rigid, square and secure.
1. **Swift #1 / Swift #3 / Swift #4 / Swift #6 / Swift #7 / Swift #10 / Auto-Sleeper #1 / Auto-Sleeper #2 / Bailey #2:** Using Item **L** with Item **M** loosely fix Items **E** to the vehicles chassis/ chassis extension. Item **G** can be used as a clamp plate on **Swift #1 / Swift #4 / Swift #6 / Swift #7 / Swift #10 / Auto-Sleeper #1 / Auto-Sleeper #2**, ensuring the chassis/ chassis extension is sandwiched between Item **D** and Item **G**. On **Swift #3 & Bailey #2** Item **G** is fitted to the vehicle as a spacer between the chassis/ chassis extension and Item **E**.
 2. Using Item **L** with Item **M** fix Items **D** to items **E**.
 3. Using Item **L** with Item **M** fix Item **A** between each side plate (Items **D**).
 4. Using Item **J** fix Item **H** (Towball) and wiring plate (Not supplied in this kit) to Item **A** ensuring Item **C** is fitted behind the face plate. (Please ensure the Towbar face plate is sandwiched between Item **C** and Item **H**).
 5. Fully tighten all fixings ensuring the Towbar is rigid, square and secure.

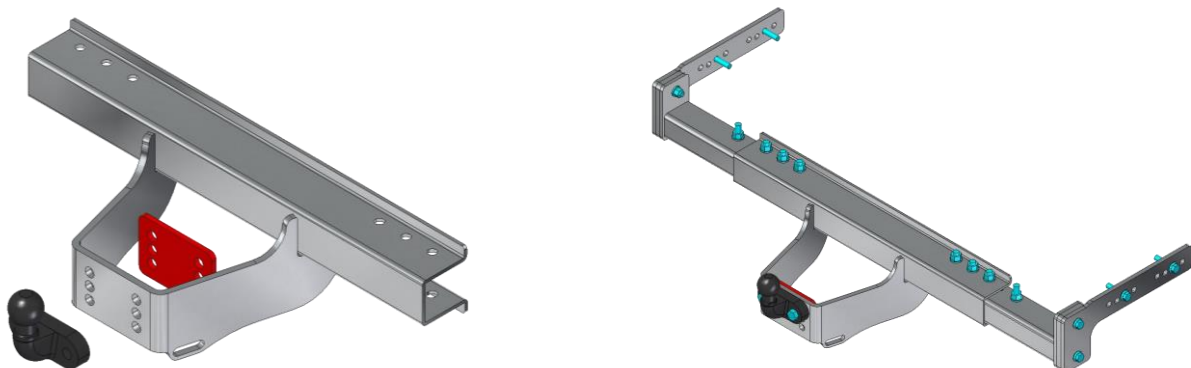

Note:

1. Recommended Torque Setting for M12 Grade 10.9 -139 Nm. (For other Torque Settings see notes overleaf.)
2. Nose load limits and vehicle manufacturers trailer / caravan weight limits must be observed.

TALKO1 Crossmember Assembly

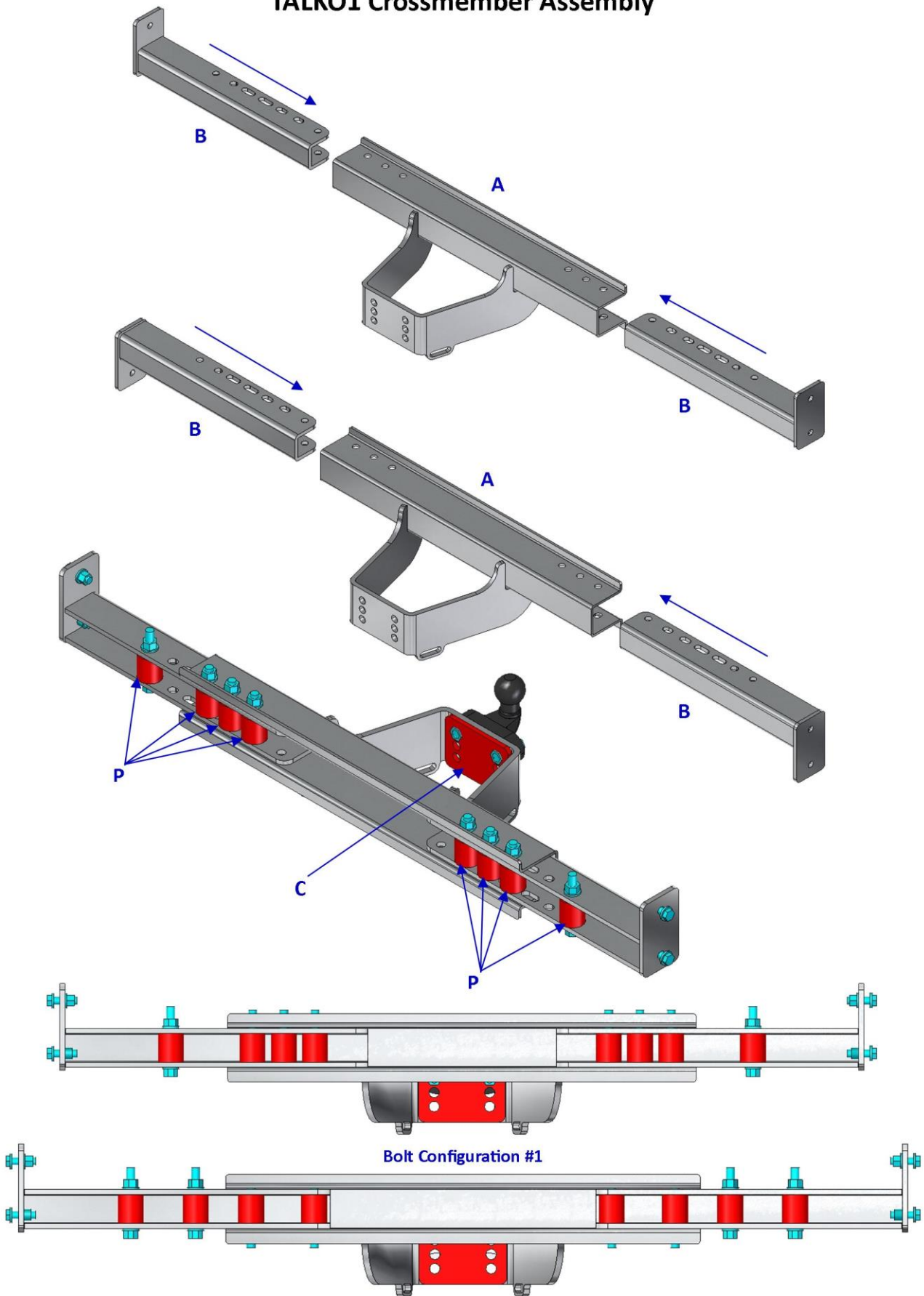

Bolt Configuration #2 1405mm CHASSIS ONLY

Parts Shown In Red Must Always Be Fitted

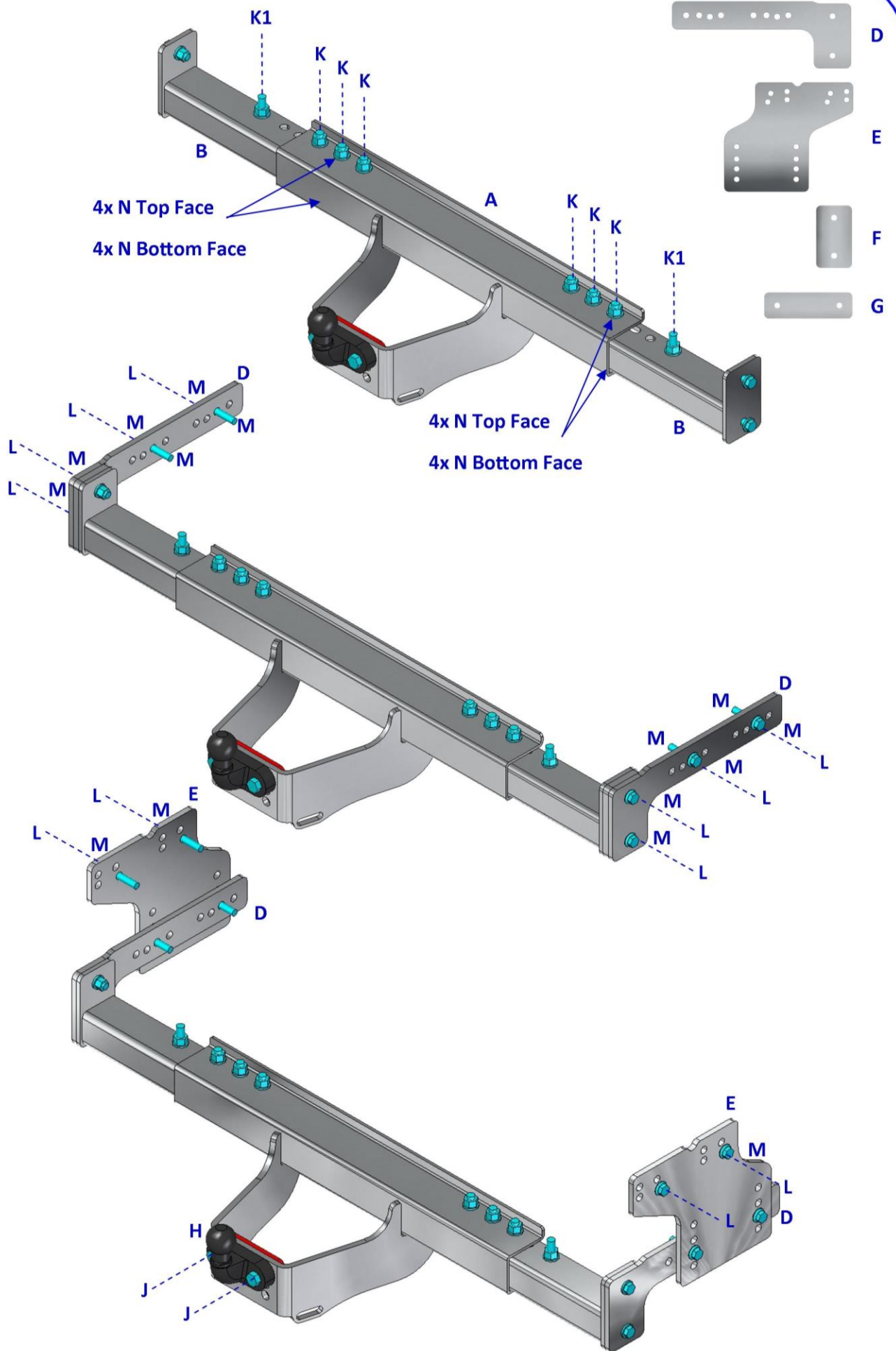

SWIFT	Bessacarr E444 (High) - MH2D
SWIFT	Hi-Style 644SD (Low) - MH2D
SWIFT	Sundance 644SD (Low) - MH2D

Swift #1

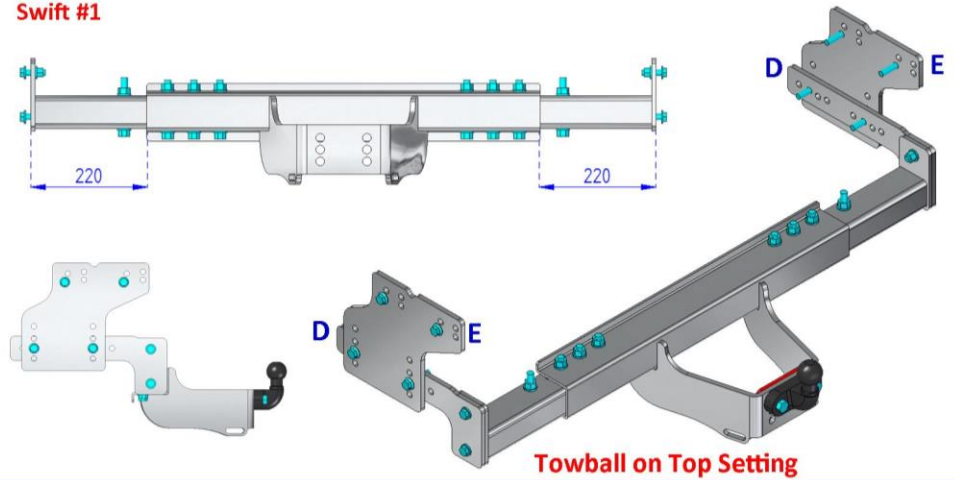

Towball on Top Setting

SWIFT	Bessacarr E496 (High) - MH2D
SWIFT	Hi-Style 636L (High) - MH2D
SWIFT	Sundance 636L (High) - MH2D

Swift #2

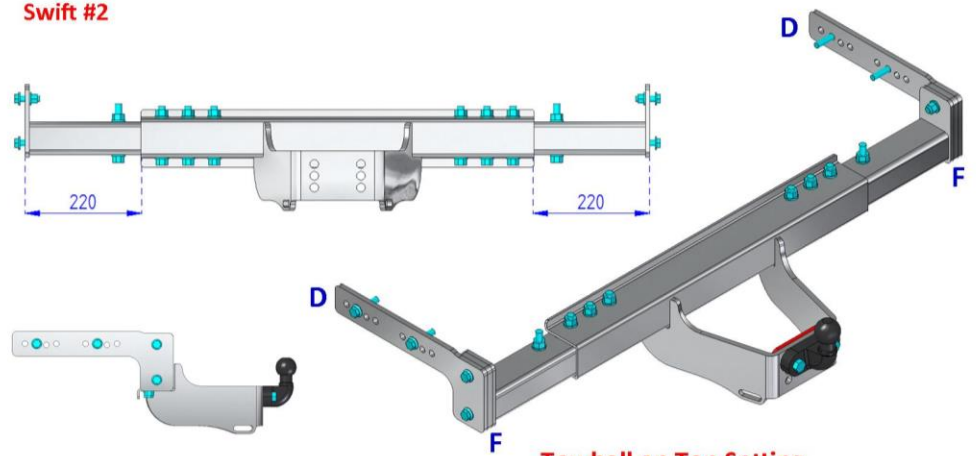

Towball on Top Setting

SWIFT	Bessacarr E520 (Low) - MH3E
SWIFT	Bessacarr E540 (Low) - MH3E
SWIFT	Bessacarr E562 (Low) - MH3E
SWIFT	Bessacarr E564 (Low) - MH3E
SWIFT	Bessacarr E572 (Low) - MH3E
SWIFT	Bessacarr E582 (Low) - MH3E
SWIFT	Bessacarr E584 (Low) - MH3E
SWIFT	Bolero 630EW (Low) - MH3E
SWIFT	Bolero 630PR (Low) - MH3E
SWIFT	Bolero 682FB (Low) - MH3E
SWIFT	Bolero 684FB (Low) - MH3E
SWIFT	Bolero 712SB (Low) - MH3E
SWIFT	Bolero 722FB (Low) - MH3E
SWIFT	Bolero 724FB (Low) - MH3E

Swift #3

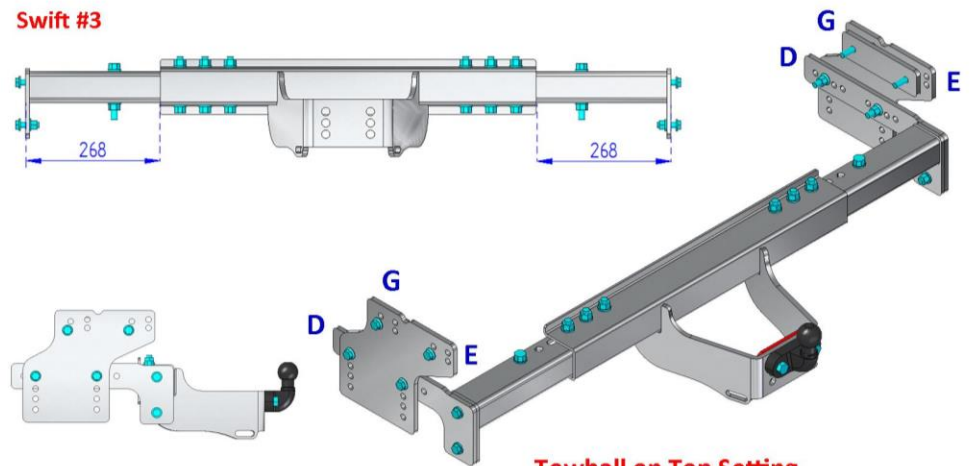

Towball on Top Setting

SWIFT	Bessacarr E412 (Low) - MH2D
SWIFT	Bessacarr E434 (High) - MH2D
SWIFT	Bessacarr E452 (Low) - MH2D
SWIFT	Bessacarr E454 (Low) - MH2D
SWIFT	Bessacarr E462 (Low) - MH2D
SWIFT	Bessacarr E464 (High) - MH2D
SWIFT	Hi-Style 532LP (Low) - MH2D
SWIFT	Hi-Style 582PR (Low) - MH2D
SWIFT	Hi-Style 584PR (High) - MH2D
SWIFT	Hi-Style 594RS (High) - MH2D
SWIFT	Hi-Style 622FB (Low) - MH2D
SWIFT	Hi-Style 624FB (Low) - MH2D
SWIFT	Sundance 532LP (Low) - MH2D
SWIFT	Sundance 582PP (Low) - MH2D
SWIFT	Sundance 584PR (High) - MH2D
SWIFT	Sundance 594RS (High) - MH2D
SWIFT	Sundance 622FB (Low) - MH2D
SWIFT	Sundance 624FB (Low) - MH2D

Swift #4

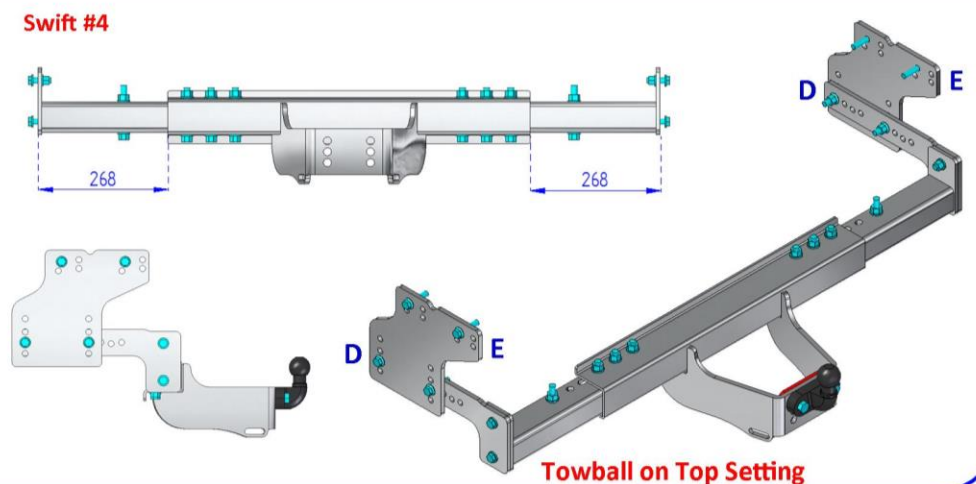

Towball on Top Setting

SWIFT	Kon-tiki 649 (Tag) (Low & High) - MH5F NOT KON-TIKI 679
SWIFT	Kon-tiki 659 (Tag) (Low) - MH5F NOT KON-TIKI 679
SWIFT	Kon-tiki 669 (Tag) (Low & High) - MH5F NOT KON-TIKI 679

Swift #5

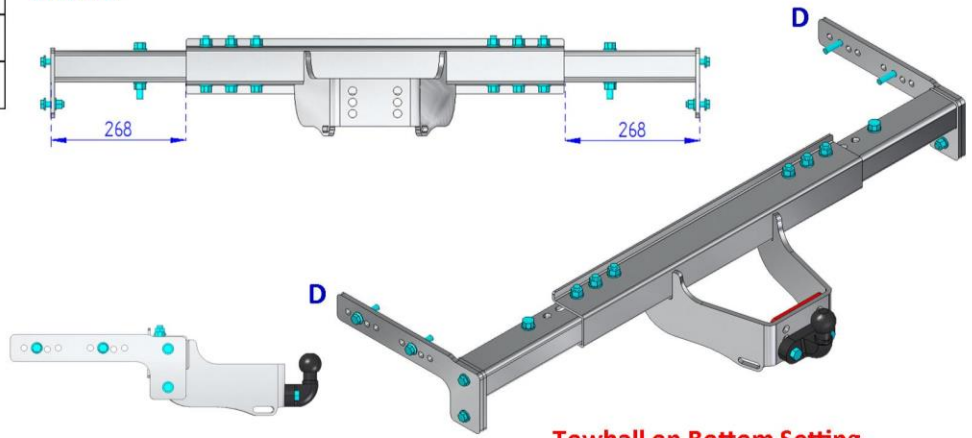

Towball on Bottom Setting

SWIFT	Escape 624 (High) - MH6D
SWIFT	Escape 644 (High) - MH6D
SWIFT	Escape 664 (Low) - MH6D
SWIFT	Lifestyle 624 (High) - MH6D
SWIFT	lifestyle 644 (High) - MH6D
SWIFT	Lifestyle 664 (low) - MH6D
AUTO-SLEEPER	Broadway NOT BROADWAY LWB MODELS / NOT VEHICLES BUILT FROM MECEDES PLATFORMS

Swift #6

Auto-Sleeper #2

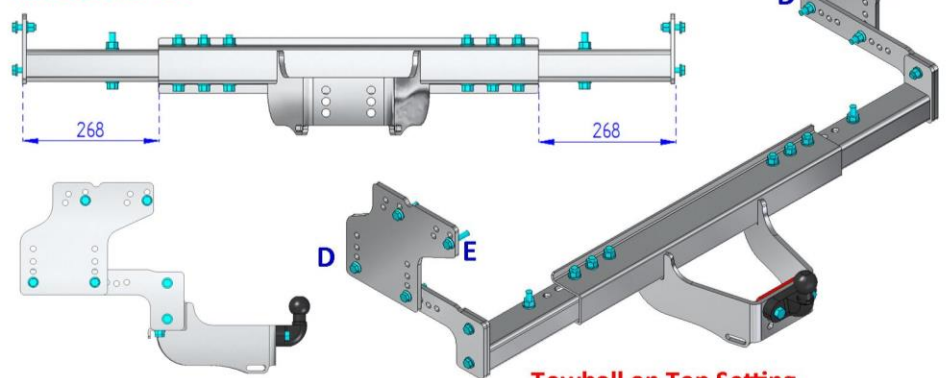

Towball on Top Setting

SWIFT	Escape 686 (High) - MH6D
SWIFT	Escape 696 (High) - MH6D
SWIFT	Lifestyle 686 (High) - MH6D
SWIFT	Espirit 412 (Low) - MH2E
SWIFT	Espirit 462 (Low) - MH2E
SWIFT	Espirit 464 (High) - MH2E
SWIFT	Espirit 454 (Low) - MH2E
SWIFT	Espirit 442 (Low) - MH2E
SWIFT	Bessacarr 412 (Low) - MH2E
SWIFT	Bessacarr 462 (Low) - MH2E
SWIFT	Bessacarr 464 (High) - MH2E
SWIFT	Bessacarr 454 (Low) - MH2E
SWIFT	Bessacarr 442 (Low) - MH2E
AUTO-SLEEPER	Nuevo NOT VEHICLES BUILT FROM MECEDES PLATFORMS

Swift #7

Auto-Sleeper #1

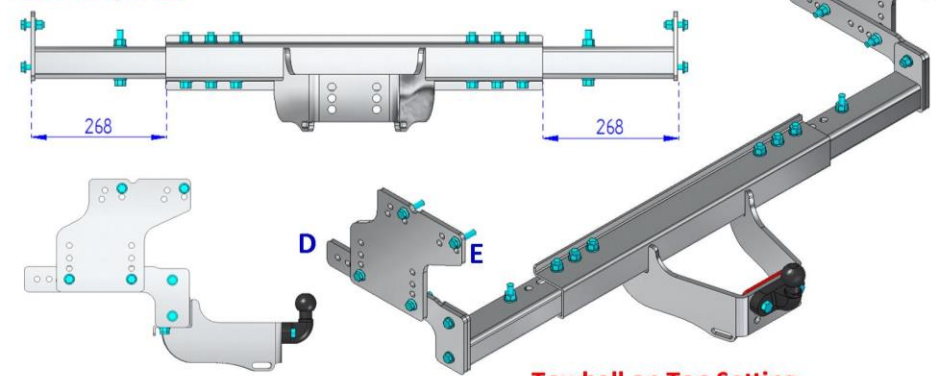

Towball on Top Setting

SWIFT	Espirit 484 (Low) - MH2E
SWIFT	Bessacarr 484 (Low) - MH2E

Swift #8

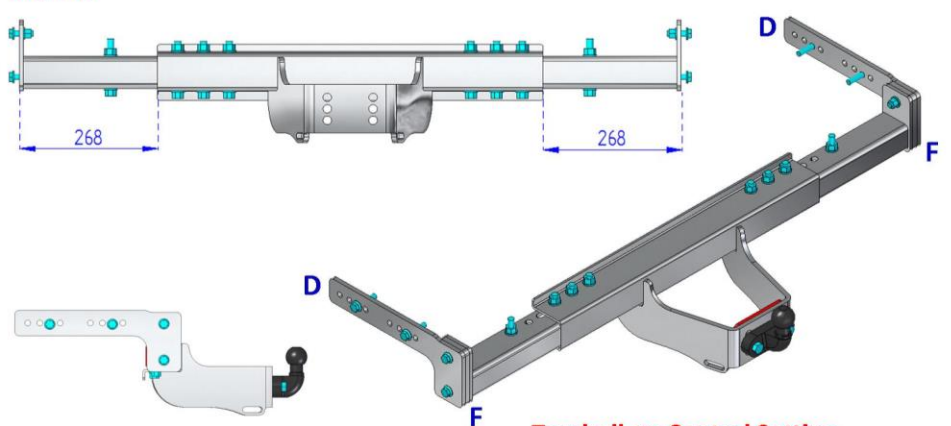

Towball on Central Setting

SWIFT	Espirit 496 (High) - MH2E
SWIFT	Bessacarr 496 (High) - MH2E

Swift #9

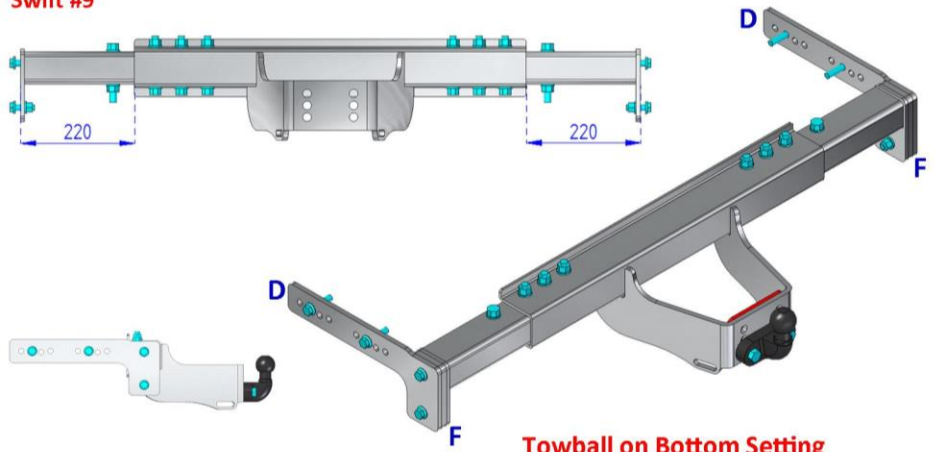

Towball on Bottom Setting

SWIFT	Espirit 444 (Low) - MH2E
SWIFT	Bessacarr 444 (Low) - MH2E

Swift #10

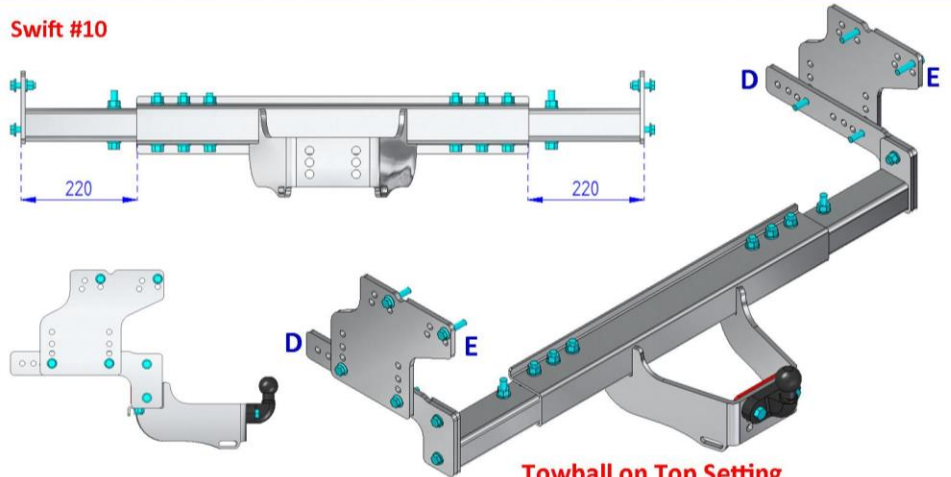

Towball on Top Setting

BAILEY	Approach Autograph 625
BAILEY	Approach Autograph 740
BAILEY	Approach Autograph 745
BAILEY	Approach Autograph 750
BAILEY	Approach Autograph 765
BAILEY	Approach Compact 520
BAILEY	Approach Compact 540

Bailey #1

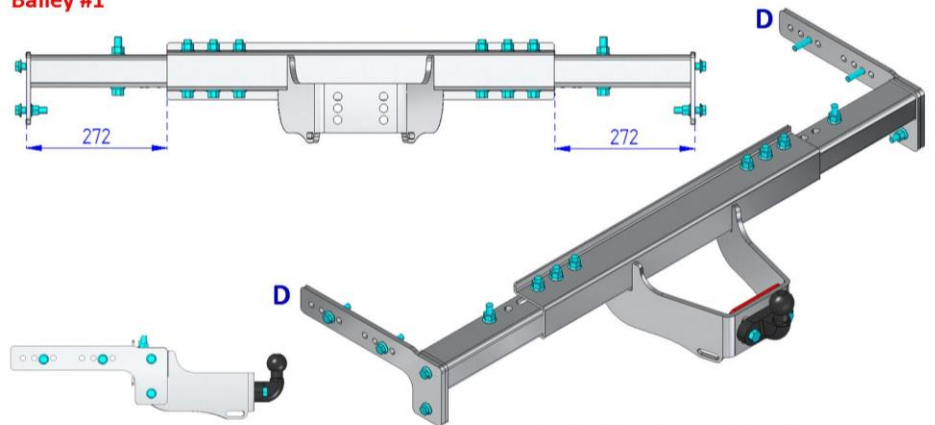

Towball on Central Setting

BAILEY	Approach SE 620
BAILEY	Approach SE 625
BAILEY	Approach SE 740
BAILEY	Approach SE 745
BAILEY	Approach SE 760

Bailey #2

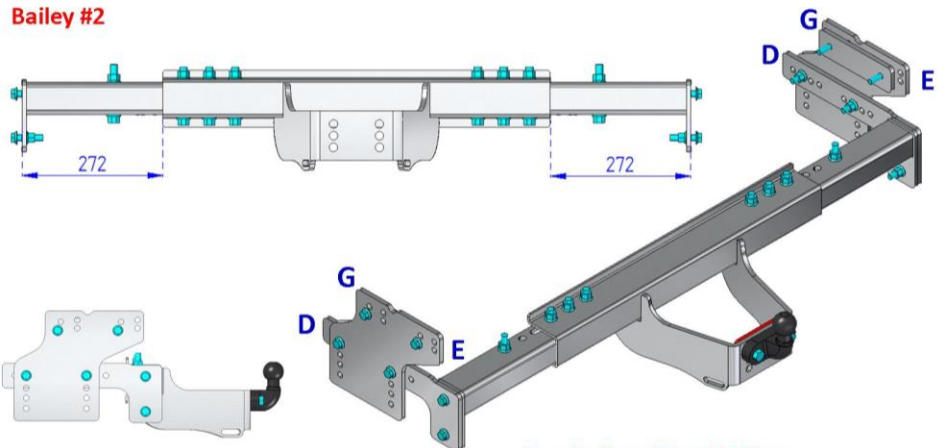

Towball on Top Setting