

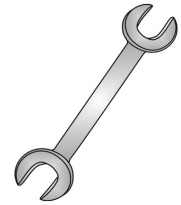

# Tow-Trust Towbars

Important: Please read General Notes overleaf before fitting



## Issue 4

TAUT1 = Apache 700 2013> / Tracker FB 2012> / Mohawk 2011> / Cherokee 2011 - 2013 / Apache 634 2011> / Navajo 2012>

TAUT2 = Tacker EKS 2012>

TAUT3 = Tacker RB 2012> / Dakota 2011> / Savannah 2011>

TAUT4 = Apache 632 / Scout 2012> / Delaware 2012>

Item	Qty	Description	Item	Qty	Description
A	1	Crossmember	F	2	M16 x 50 Bolts, Nuts & S/P Washers
B	2	Side Arms	G	16	M12 x 40 Bolts, 14 Nyloc Nuts & 2 S/P Washers
C	1	R/H Chassis Bracket	H	6	M10 x 40 Bolts & Nyloc Nuts
D	1	L/H Chassis Bracket	J	2	M12 x 140 Bolts & Nyloc Nuts
E	2	Chassis Angle Brackets	K	20	12 x 25 Flat Washers
			L	6	10 x 25 Flat Washers
			M	4	12 x 40 Flat Washers
			N	1	Std. Towball (ATT-T1)
			Q	1	Socket Plate 5

1. Where fitted remove the rear crossmember and the rear braces and discard.
2. Loosely attach each side arm (Item **B**) to each chassis member using Item **G** and Item **K**.  
**NOTE:** On vehicles with body supports, remove the rearmost fixings, and loosen the front fixings, this will allow the spacer plates to be removed and the side arms (Item **B**) to be inserted.
3. Using Item **G** with Item **K** fix the crossmember (Item **A**) between each side arm (Items **B**).
4. Remove the central fixings from the chassis drop arms (**Point X** 2x M10 Fixings each side).
5. Using Item **J** with Item **M** fix each chassis bracket (Item **C** & Item **D**) to each correct chassis member.
6. Using Item **H** with Item **L** fix each chassis bracket to each chassis drop bracket (Point X).
7. Using Item **H** with Item **L** fix Items **E** to each chassis drop bracket and to Items **C** & **D** (**FIG.1** O/S Chassis & **FIG.2** N/S Chassis).
8. Using Item **F** bolt your desired ball bracket and wiring plate to Item **A**.
9. Fully tighten all fixings until Towbar is rigid, square, and secure.

### Note:

1. Recommended Torque Setting for M12 Grade 10.9 -130 Nm. (For other Torque Settings see notes overleaf.)
2. Nose load limits and vehicle manufacturers trailer / caravan weight limits must be observed.

# TAUT1

Autotrail Motorhomes

Apache 700 2013>

Tracker FB 2012>

Mohawk 2011>

Cherokee 2011—2013

Apache 634 2011>

Navajo 2012>

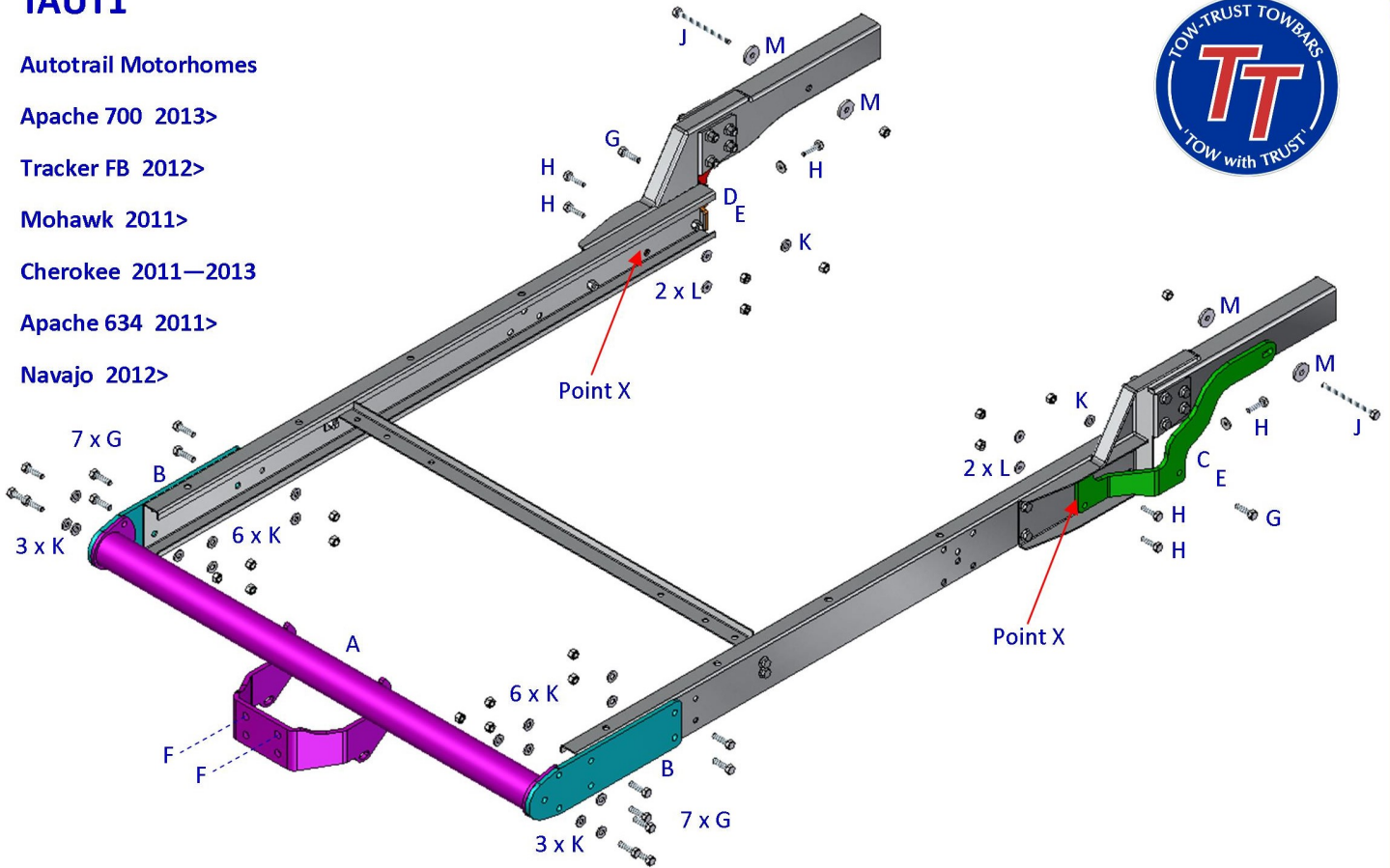

# TAUT2

Tracker EKS 2012>

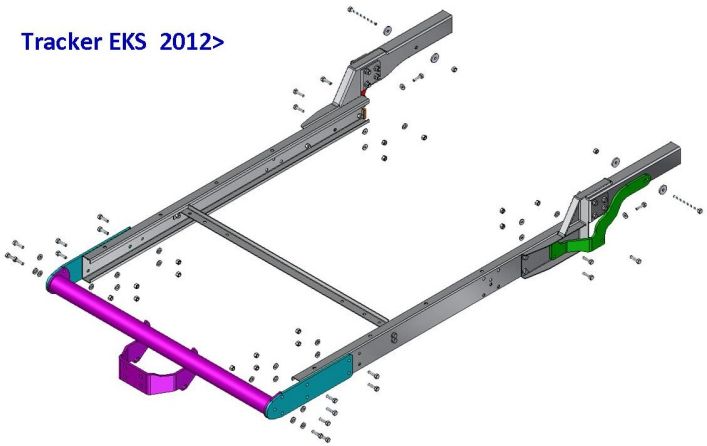

# TAUT3

Tracker RB 2012>

Dakota 2011>

Savannah 2011>

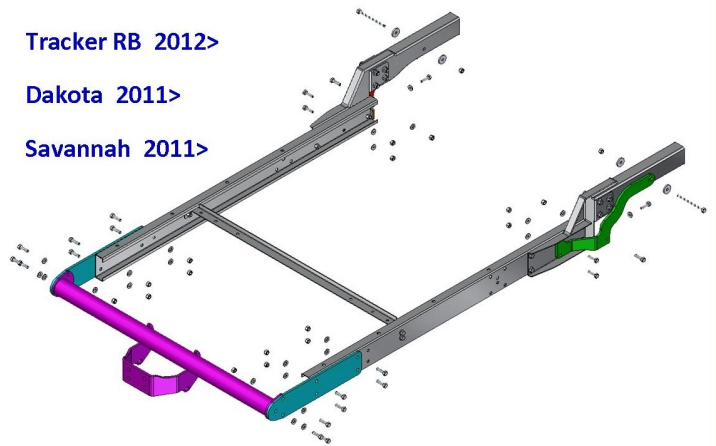

# TAUT4

Apache 632 2011>

Scout 2012>

Delaware 2012>

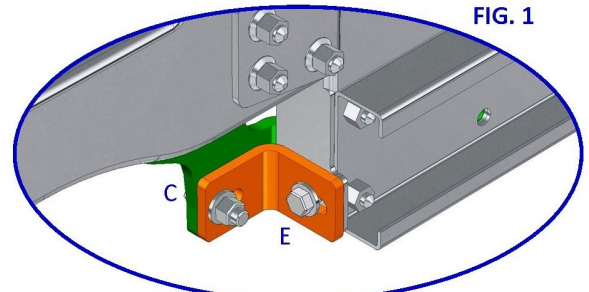
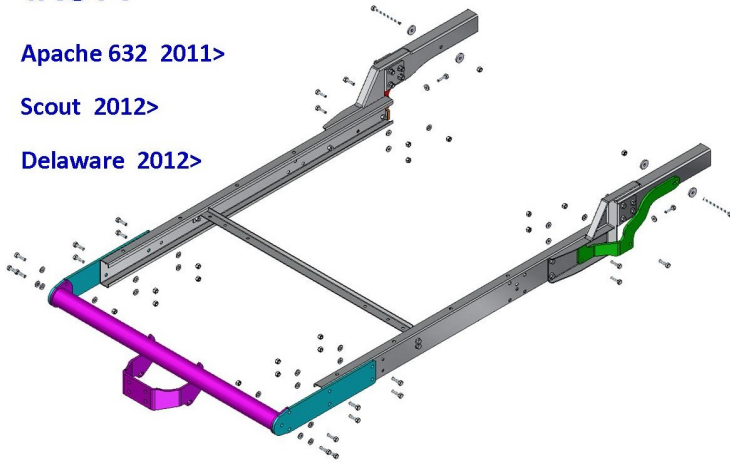

FIG. 1

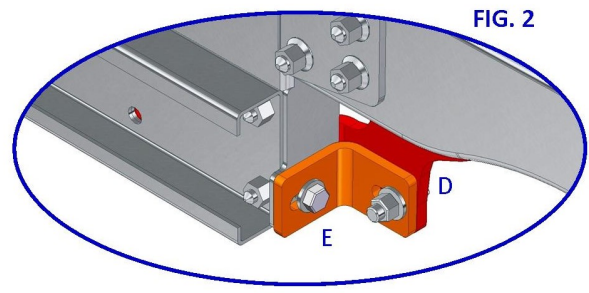

FIG. 2