



# Tow-Trust Towbars

Important: Please read General Notes overleaf before fitting  
Issue: 1



Fitting  
Instruction

## TAUT6SN-9203 Autotrail F-Line Motorhomes 2019> & Ford Skeletal Chassis Based Vehicles Up To 4100 GVW With Maximum Towing Capacity 1750 kg 2014>

Item	Qty	Description	Item	Qty	Description
A	1	TAUT6 Crossbar	H	1	VASP8/RH
B	2	Side Arm	J	2	15 mm Spacer Plates
C	4	19 mm O/D 52 mm Long Spacer Tubes	K	2	M12 x 110 Bolt (10.9) & Nyloc Nuts
D	4	19 mm O/D 60 mm Long Spacer Tubes	L	4	M12 x 45 Bolts & Nyloc Nuts
E	2	Chassis Spacer Plate	M	8	M12 x 90 Bolts & Nyloc Nuts
F	1	ACS3 / 9203 Swan Neck	N	24	12 x 25 Flat Washers
			P	4	12 x 40 Flat Washers

### TOWBAR INSTALLATION:

1. Remove the four fixings at the rearmost mounting points. (Autotrail Models F60/F62, these Models will not use item E).
2. Loosely attach items **B** to the inside face of each chassis, with items **E** as spacers at the rearmost mounting point on the skeletal chassis and fix in place using items **M** with items **N** and items **P** with items **C** and **D** inserted into the chassis. (Note: Items **C** are inserted through the ends of the chassis and items **D** through the side face).
3. Using items **L** with items **N** loosely fix item **A** to items **B**.
4. Using items **K** with items **N** and item **H** with items **J** fix item **F** to item **A**.
5. Fully tighten all fixings ensuring the Towbar is rigid, square and secure.

Figure 1

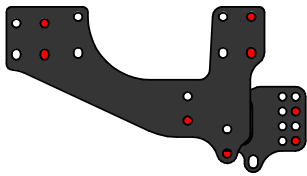

Autotrail F-Line Setting  
F60 and F62

Figure 2

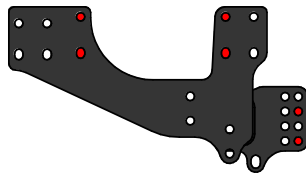

Setting For Use With  
TAUT6-EXT Only

Figure 3

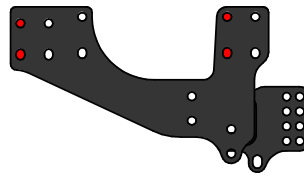

Skeletal Chassis  
Setting One

Figure 4

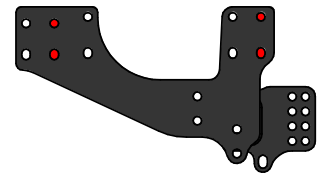

Skeletal Chassis  
Setting Two

When Fitting To Models With Chassis Extensions, Order TAUT6-CSK In Addition For Full Installation

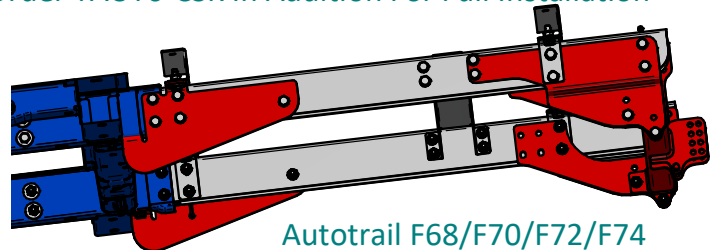
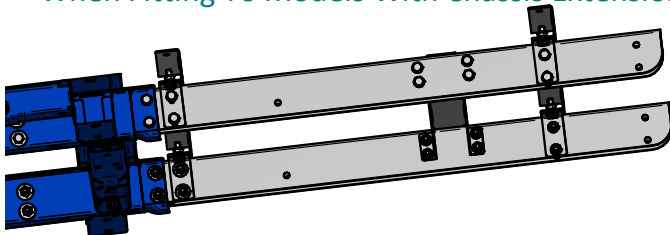

Autotrail F68/F70/F72/F74

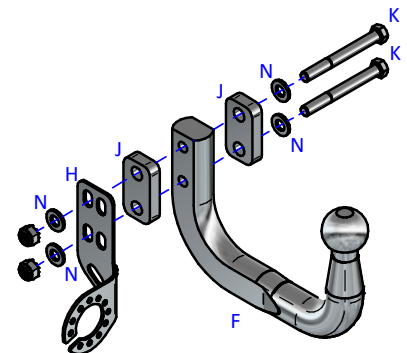
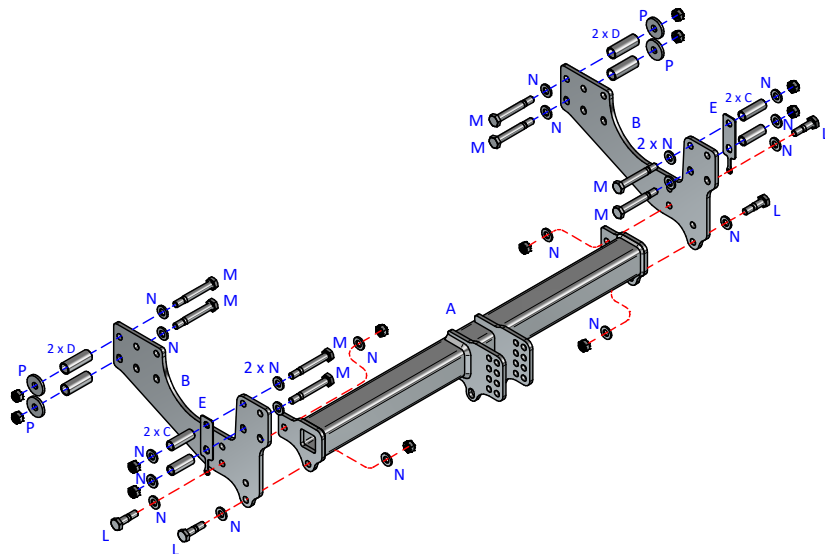

### Notes:

1. For Torque settings see general notes overleaf.
2. Nose load limits and vehicle manufacturer's trailer / caravan weight limits must be observed.
3. We recommend the use of PRO-TOW Couplings with all our products.