



Tow-Trust Towbars

Important: Please read General Notes overleaf before fitting
Issue: 1



Fitting
Instruction

TAUT6VK-6224 Autotrail F-Line Motorhomes 2019> & Ford Skeletal Chassis Based Vehicles 2014>

Item	Qty	Description	Item	Qty	Description
A	1	TAUT6 Crossbar	H	1	Flip Up Socket Plate (TTFP/LH)
B	2	Side Arm	J	2	M12 x 22 Bolts & S/P Washers
C	4	19 mm O/D 52 mm Long Spacer Tubes	K	2	M12 x 25 Bolts & S/P Washers
D	4	19 mm O/D 60 mm Long Spacer Tubes	L	4	M12 x 45 Bolts & Nyloc Nuts
E	2	Chassis Spacer Plate	M	8	M12 x 90 Bolts & Nyloc Nuts
F	1	6224 Detachable Neck	N	20	12 x 25 Flat Washers
			P	4	12 x 40 Flat Washers

TOWBAR INSTALLATION:

1. Remove the four fixings at the rearmost mounting points. (Autotrail Models F60/F62, these Models will not use item E).
2. Loosely attach items B to the inside face of each chassis, with items E as spacers at the rearmost mounting point on the skeletal chassis and fix in place using items M with items N and items P with items C and D inserted into the chassis. (Note: Items C are inserted through the ends of the chassis and items D through the side face).
3. Using items L with items N loosely fix item A to items B.
4. Using items J and items K with items N and item H fix item F to item A.
5. Fully tighten all fixings ensuring the Towbar is rigid, square and secure.

Figure 1

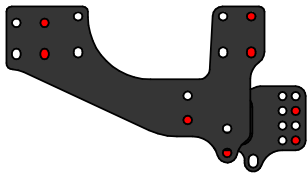

Autotrail F-Line Setting
F60 and F62

Figure 2

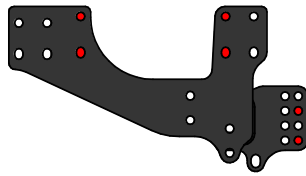

Setting For Use With
TAUT6-EXT Only

Figure 3

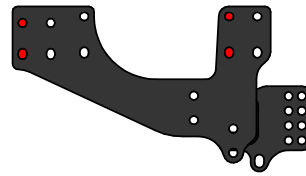

Skeletal Chassis
Setting One

Figure 4

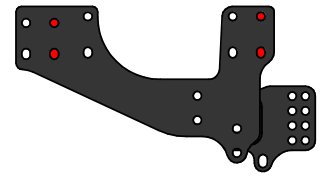

Skeletal Chassis
Setting Two

When Fitting To Models With Chassis Extensions, Order TAUT6-CSK In Addition For Full Installation

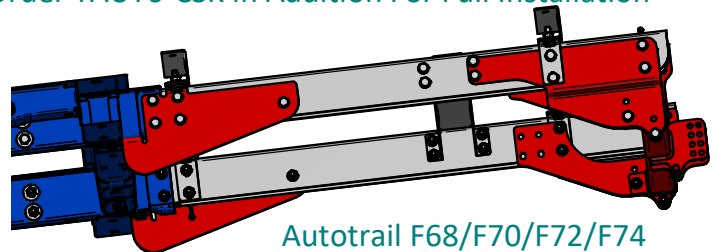
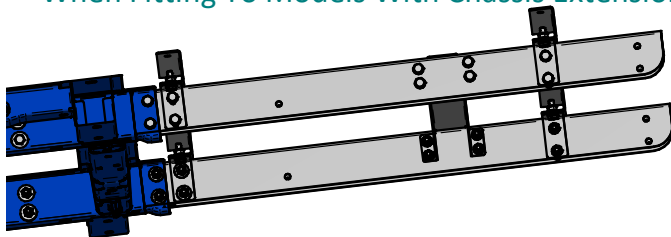

Autotrail F68/F70/F72/F74

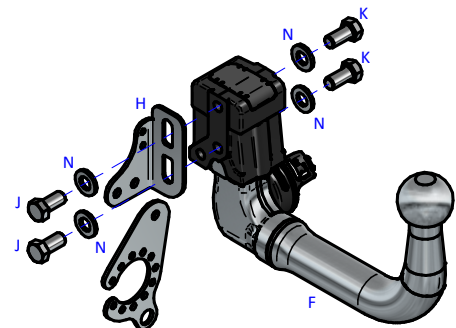
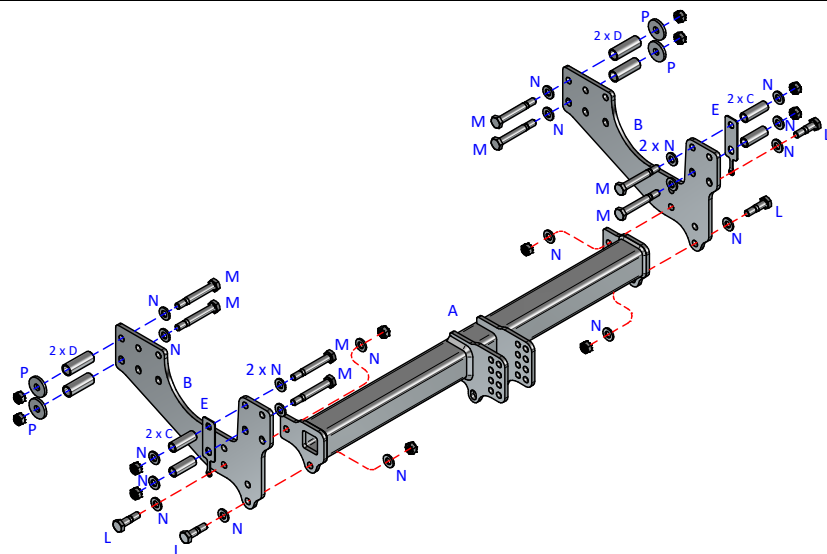

Notes:

1. For Torque settings see general notes overleaf.
2. Nose load limits and vehicle manufacturer's trailer / caravan weight limits must be observed.
3. We recommend the use of PRO-TOW Couplings with all our products.